

Hydra-Comp

HFR2S cylinder Ø25/16

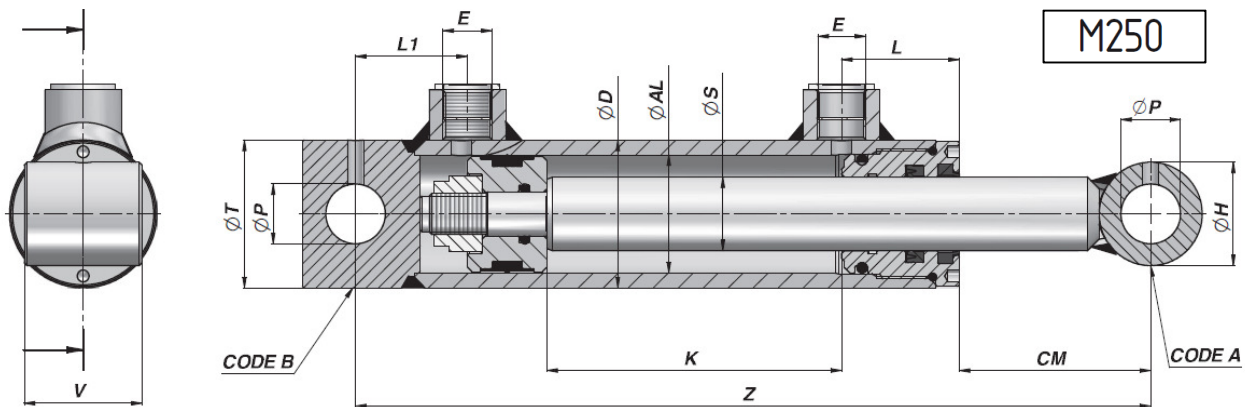

Dobbeltvirkende / Double acting

Max hastighed / Max speed: 0,5m/s

Arbejdstryk / Work pressure: 200 Bar

Spidstryk / Peak pressure: 250Bar

Temperatur / Temperature: -25°C - +80°C

Stempelstang / Piston rod: UNI C45 steel SAE 1045with 25µ +/-5 hard chrome

Rør / Tube: st 52-3 DIN 2393 ISO H9

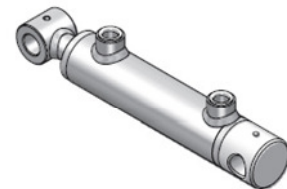

Codice Code Bestell-Nr.	K	Z	kg	E BSP	L	L1	CM	ØP	ØH	V	ØT
ØD 35 ØAL 25 ØS 16											
HFR0160050	50	160	1,00								
HFR0160100	100	210	1,20								
HFR0160150	150	260	1,40	1/4"	33	22	31	12,1	25	25	35
HFR0160200	200	310	1,70								

www.hydra-comp.com