

# Hydra-Comp

## HFR2S cylinder Ø32/20

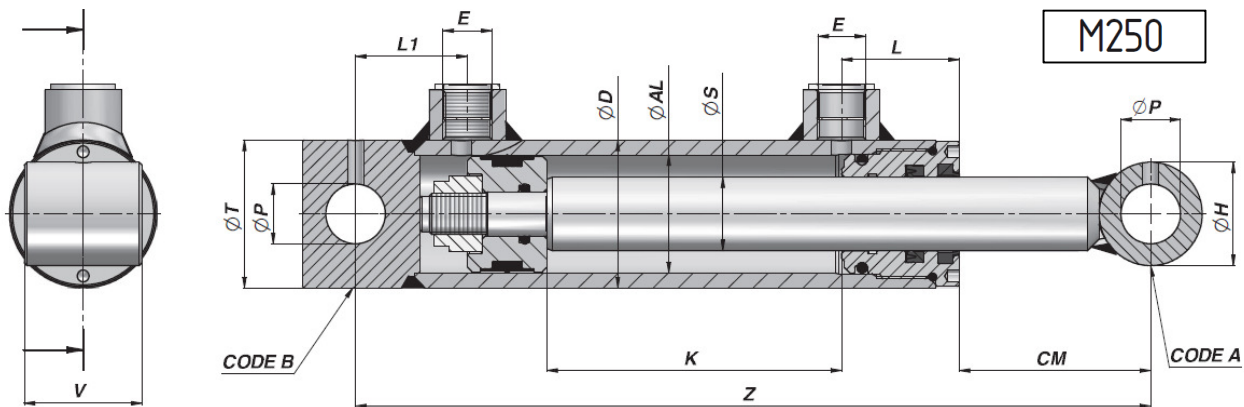

Dobbeltvirkende / Double acting

Max hastighed / Max speed: 0,5m/s

Arbejdstryk / Work pressure: 200 Barp

Spidstryk / Peak pressure: 250Bar

Temperatur / Temperature: -25°C - +80°C

Stempelstang / Piston rod: UNI C45 steel SAE 1045with 25µ +/-5 hard chrome

Rør / Tube: st 52-3 DIN 2393 ISO H9

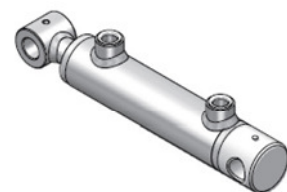

Codice Code Bestell-Nr.	K	Z	kg	E BSP	L	L1	CM	ØP	ØH	V	ØT
<b>ØD 42    ØAL 32    ØS 20</b>											
HFR0200050	50	205	1,70	1/4"	33	35	51	16,2	30	35	40
HFR0200100	100	255	2,10								
HFR0200150	150	305	2,40								
HFR0200200	200	355	2,80								
HFR0200250	250	405	3,10								
HFR0200300	300	455	3,50								
HFR0200400	400	555	4,20								
HFR0200500	500	655	4,80								

[www.hydra-comp.com](http://www.hydra-comp.com)