

Hydra-Comp

HFR2S cylinder Ø70/40

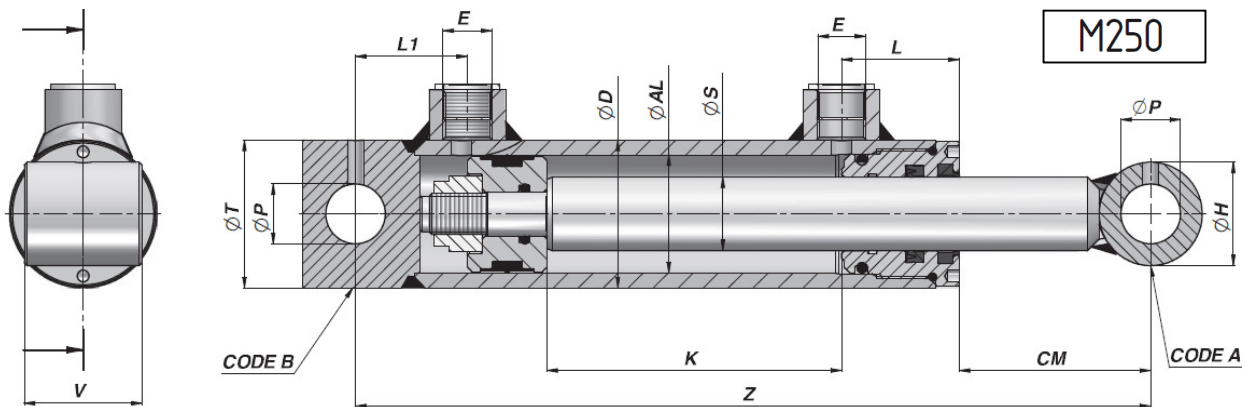

Dobbeltvirkende / Double acting

Max hastighed / Max speed: 0,5m/s

Arbejdstryk / Work pressure: 200 Bar

Spidstryk / Peak pressure: 250Bar

Temperatur / Temperature: -25°C - +80°C

Stempelstang / Piston rod: UNI C45 steel SAE 1045with 25µ +/-5 hard chrome

Rør / Tube: st 52-3 DIN 2393 ISO H9

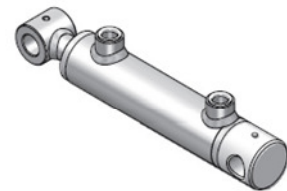

Codice Code Bestell-Nr.	K	Z	kg	E BSP	L	L1	CM	ØP	ØH	V	ØT
ØD 80 ØAL 70 ØS 40											
HFR2S0700400200	200	410	10,10								
HFR2S0700400250	250	460	11,00								
HFR2S0700400300	300	510	12,00								
HFR2S0700400350	350	560	13,00								
HFR2S0700400400	400	610	13,90								
HFR2S0700400450	450	660	14,90	3/8"	50	46	82	30,25	50	55	80
HFR2S0700400500	500	710	15,80								
HFR2S0700400600	600	810	17,70								
HFR2S0700400700	700	910	19,60								
HFR2S0700400800	800	1010	21,50								
HFR2S0700400900	900	1110	23,40								

www.hydra-comp.com