

Hydra-Comp

HFR2S cylinder Ø80/40

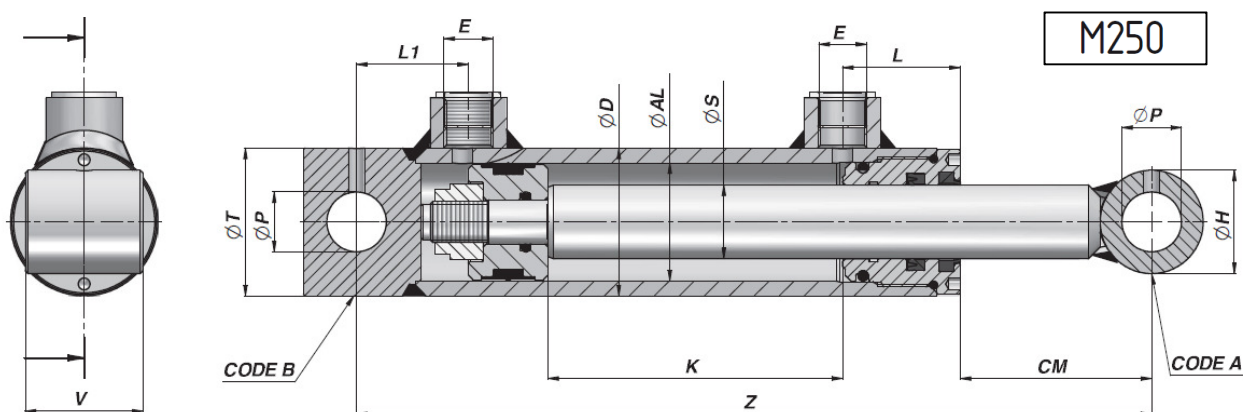

Dobbeltvirkende / Double acting

Max hastighed / Max speed: 0,5m/s

Arbejdstryk / Work pressure: 200 Bar

Spidstryk / Peak pressure: 250Bar

Temperatur / Temperature: -25°C - +80°C

Stempelstang / Piston rod: UNI C45 steel SAE 1045with 25µ +/-5 hard chrome

Rør / Tube: st 52-3 DIN 2393 ISO H9

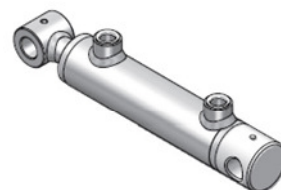

Code Code Bestell-Nr.	K	Z	kg	E BSP	L	L1	CM	ØP	ØH	V	ØT
ØD 92 ØAL 80 ØS 40											
HFR2S0800400200	200	410	13,00								
HFR2S0800400250	250	460	14,20								
HFR2S0800400300	300	510	15,30								
HFR2S0800400350	350	560	16,40								
HFR2S0800400400	400	610	17,50								
HFR2S0800400500	500	710	19,80	3/8"	60	42	70	30,25	50	55	90
HFR2S0800400600	600	810	22,00								
HFR2S0800400700	700	910	24,30								
HFR2S0800400800	800	1010	26,50								
HFR2S0800400900	900	1110	28,80								
HFR2S0800401000	1000	1210	31,00								

www.hydra-comp.com