

# Hydra-Comp

## HT0 plunger cylinder Ø40

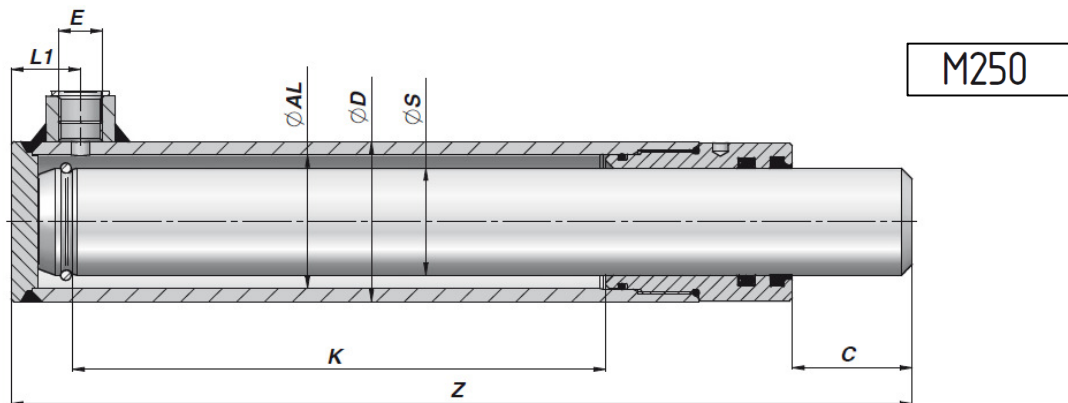

Enkeltvirkende / Singel acting

Max hastighed / Max speed: 0,5m/s

Arbejdstryk / Work pressure: 200 Bar

Spidstryk / Peak pressure: 250Bar

Temperatur / Temperature: -25°C - +80°C

Stempelstang / Piston rod: UNI C45 steel SAE 1045with 25µ +/-5 hard chrome

Rør / Tube: st 52-3 DIN 2393 ISO H9



Codice Code Bestell-Nr.	K	Z	kg	E BSP	L1	C
	<b>ØD 60</b>	<b>ØAL 50</b>	<b>ØS 40</b>			
HT03400200	200	338	5,64	3/8"	26	45
HT03400300	300	438	7,29			
HT03400400	400	538	8,98			
HT03400500	500	638	10,61			
HT03400600	600	738	12,28			