

Hydra-Comp

HT0 plunger cylinder Ø50

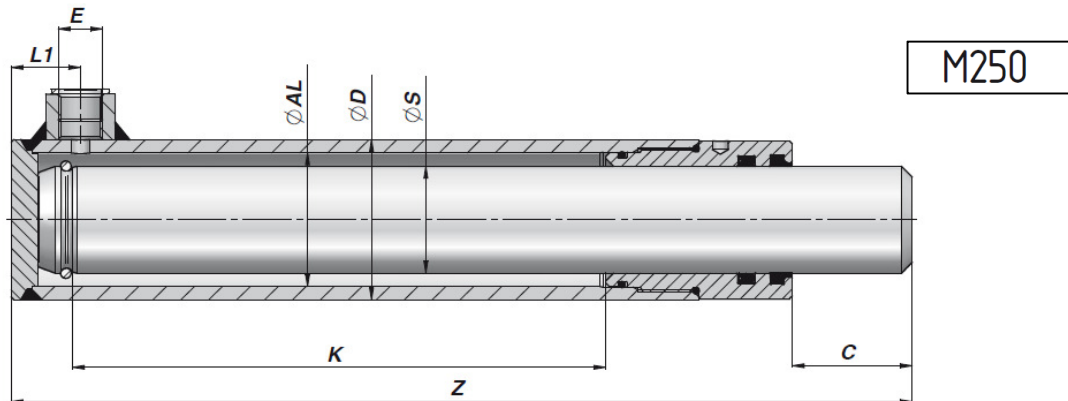

Enkeltvirkende / Singel acting

Max hastighed / Max speed: 0,5m/s

Arbejdstryk / Work pressure: 200 Bar

Spidstryk / Peak pressure: 250Bar

Temperatur / Temperature: -25°C - +80°C

Stempelstang / Piston rod: UNI C45 steel SAE 1045with 25µ +/-5 hard chrome

Rør / Tube: st 52-3 DIN 2393 ISO H9



Codice Code Bestell-Nr.	K	Z	kg	E BSP	L1	C
	ØD 70	ØAL 60	ØS 50			
HT04500300	300	450	10,47	3/8"	30	50
HT04500400	400	550	12,86			
HT04500500	500	650	15,14			
HT04500600	600	750	17,50			