



Light duty cylinder, pins - ball

Part Number

3104951605001

Tipping weight

17-29 ton

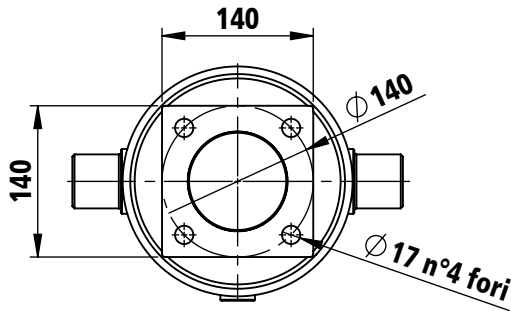
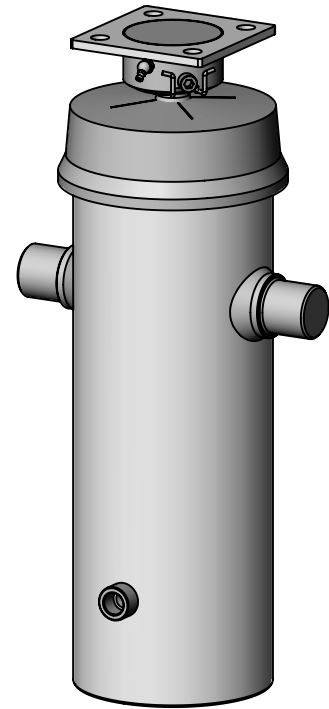
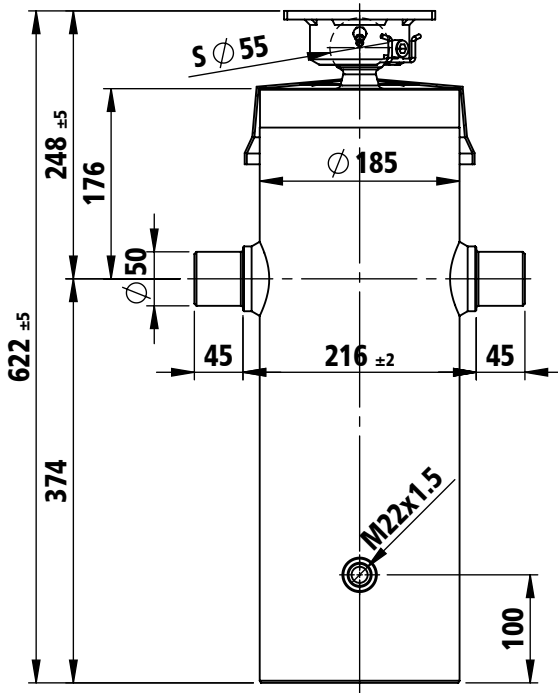

mounting dimension	248 mm + 20 mm min pull out					total stroke	2156 mm	max pressure	180 bar	
model: BL495 2156 160 5 CRL	code: 3104951605001					weight: 82 kg	1222 000748			
extension	1	2	3	4	5	-	-	-	-	number of stages: 5
diameter [mm]	160	140	120	105	90	--	--	--	--	
stroke [mm]	430	437	434	434	421	--	--	--	--	total: 2156 mm
thrust [kN]	362	277	204	156	115	--	--	--	--	max thrust admitted: 171 kN
oil [dm³]	8.6	6.7	4.9	3.8	2.7	--	--	--	--	total: 26.7 dm³

TECHNICAL NOTES AND SPECIFICATIONS

- The normal application of telescopic cylinder is to lift up tipping bodies, loaded with different materials, and consequently discharge this material whilst the cylinder is extended all along its stroke.
- The body weight plus the max payload are the max tipping weight that can be raised by the cylinder. This value, calculated at the max pressure, is a rough indication of the tipping power of the cylinder and must be used as a first criteria for the selection of the cylinder. The real tipping mass can only be calculated by the design engineer of the dump truck, and must take into account the geometry of the dump body and operating conditions. Never exceed the maximum thrust.
- Never exceed maximum pressure.
- The cylinder has been designed for loads along the longitudinal axis: the cylinder is a lifting device only and may not be used as structural member or be subject to side load.
- Chrome coating type CRL (minimum thickness: 5 µm) on telescopic stages.
- Chrome coating type CRN (40 h corrosion test ISO 9227-rating 9 ISO 10289/minimum thickness: 15 µm) on rod stage Ø90.
- H.S.PENTA warranty does not apply to any kind of corrosion of coated or non-coated parts. See terms of warranty.
- Maximum extension speed less than 0.2 m/s.
- Hydraulic oil temperature admitted between -40°C and +100°C.
- In case the cylinders must be stored, do not remove the package. Store them in a dry place, not exposed to rain. Do not store the cylinders for more than 6 (six) months.
- Further specifications see mounting instructions, hydraulic oil specification sheet, user & maintenance manual.

REMARKS

[2012.01.16] [----,---,--]

Chromed stages (Steli cromati)

REVISIONS

.	01
	02
	03
	04